

**FINISHING MOWERS
SGM V1 / SMGM SERIES**

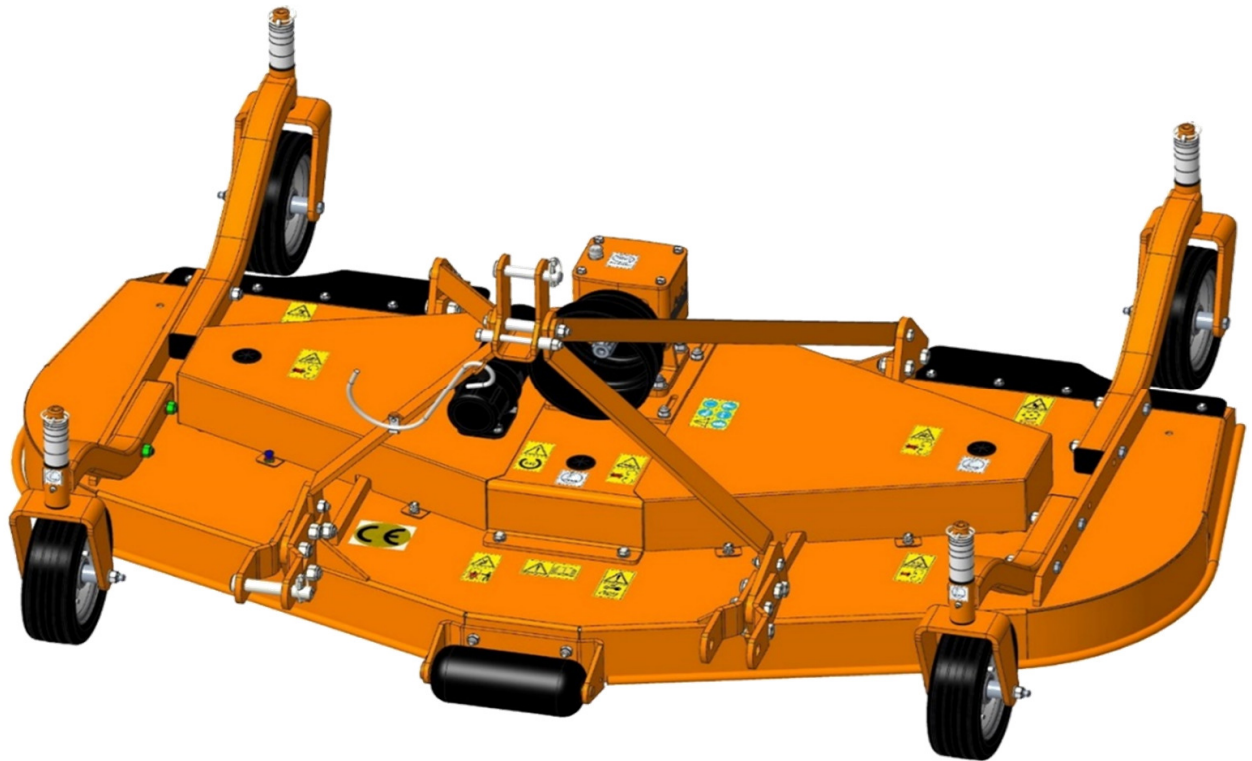

FINISHING MOWER (SGM)

SGM 120 | SGM 150 | SGM 180 | SGM 210

PART'S MANUAL



PM2812-21EN-001_SEP_19

INDEX

Page No.	Description	Revision Date
1.1	KIT FRAME ASSEMBLY	PM2812-21EN-001_REV_000_SEP_19
1.2	KIT FRAME ASSEMBLY	PM2812-21EN-001_REV_000_SEP_19
1.3	KIT FRAME ASSEMBLY	PM2812-21EN-001_REV_000_SEP_19
1.4	KIT FRAME ASSEMBLY	PM2812-21EN-001_REV_000_SEP_19
2.1	GEAR BOX ASSEMBLY	PM2812-21EN-001_REV_000_SEP_19
2.2	GEAR BOX ASSEMBLY	PM2812-21EN-001_REV_000_SEP_19
3.1	SPINDLE ASSEMBLY (6205/6206)	PM2812-21EN-001_REV_000_SEP_19
3.2	SPINDLE ASSEMBLY (6205/6206)	PM2812-21EN-001_REV_000_SEP_19
4.1	WHEEL ASSEMBLY	PM2812-21EN-001_REV_000_SEP_19
4.2	WHEEL ASSEMBLY	PM2812-21EN-001_REV_000_SEP_19
5.1	KIT 3- POINT ATTACHMENT	PM2812-21EN-001_REV_000_SEP_19
5.2	KIT 3- POINT ATTACHMENT	PM2812-21EN-001_REV_000_SEP_19
6.1	MULCHING KIT ASSEMBLY	PM2812-21EN-001_REV_000_SEP_19
6.2	MULCHING KIT ASSEMBLY	PM2812-21EN-001_REV_000_SEP_19

KIT FRAME ASSEMBLY | FOR 1.5, 1.8 & 2.1M

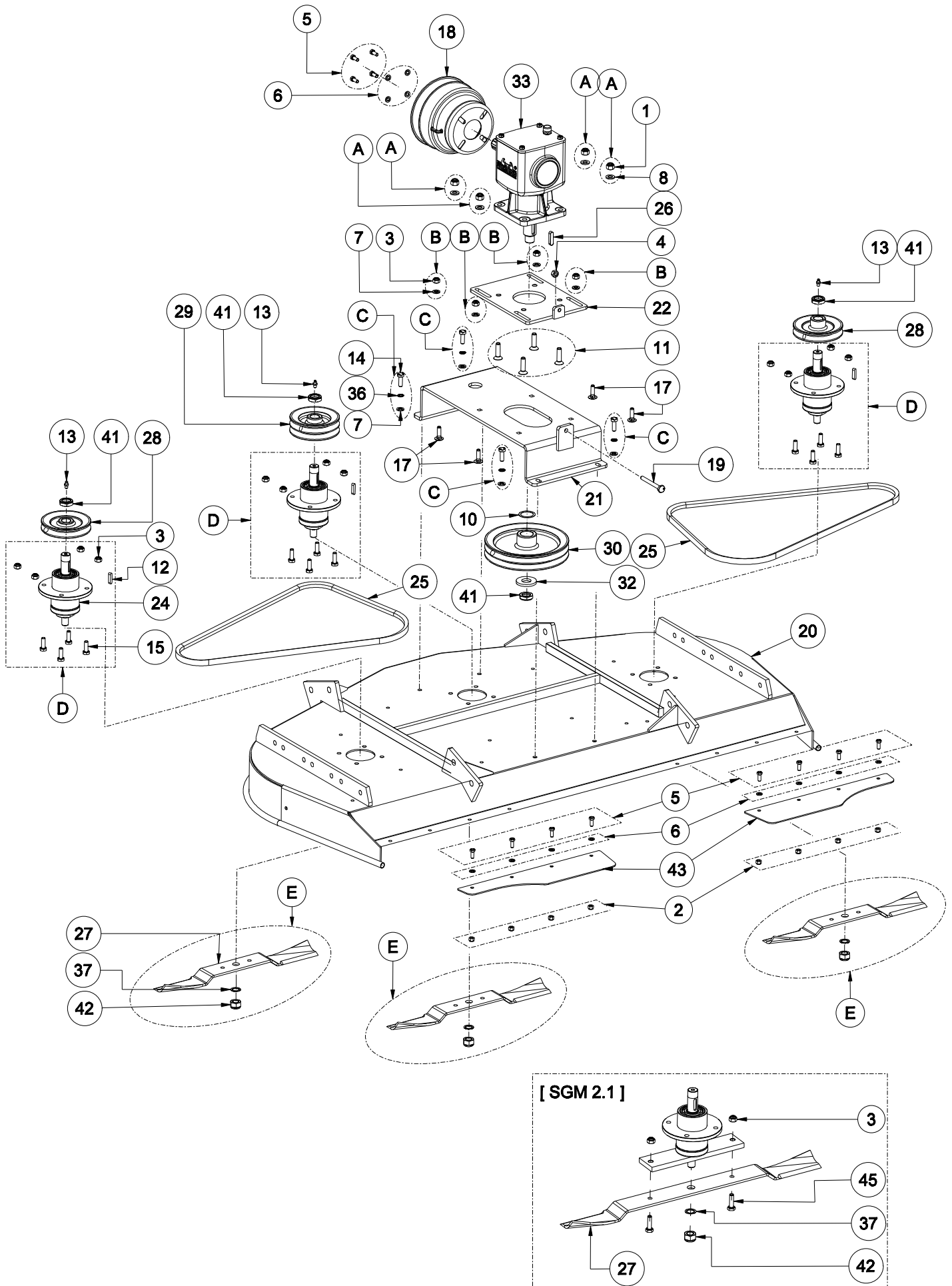

KIT FRAME ASSEMBLY | FOR 1.5, 1.8 & 2.1M

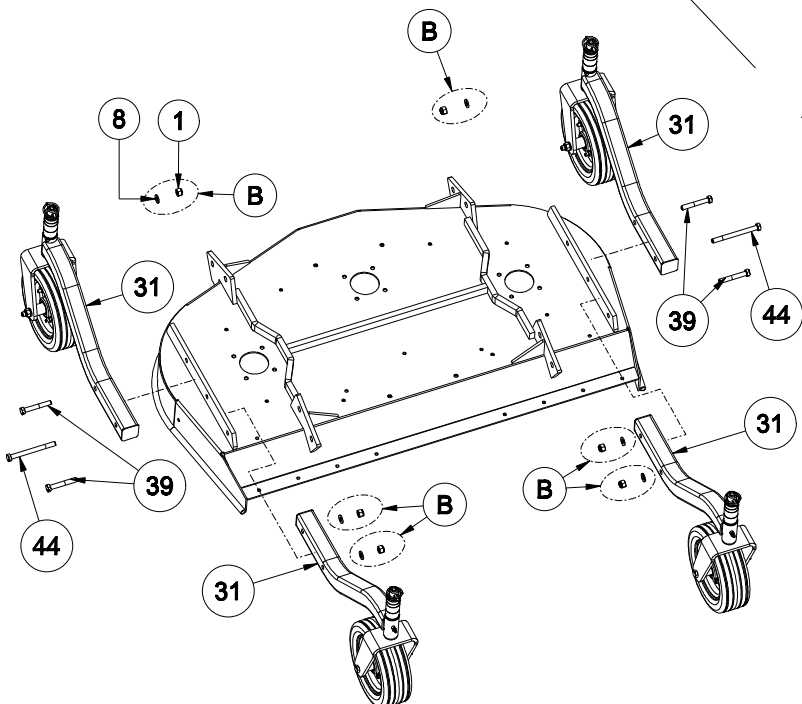
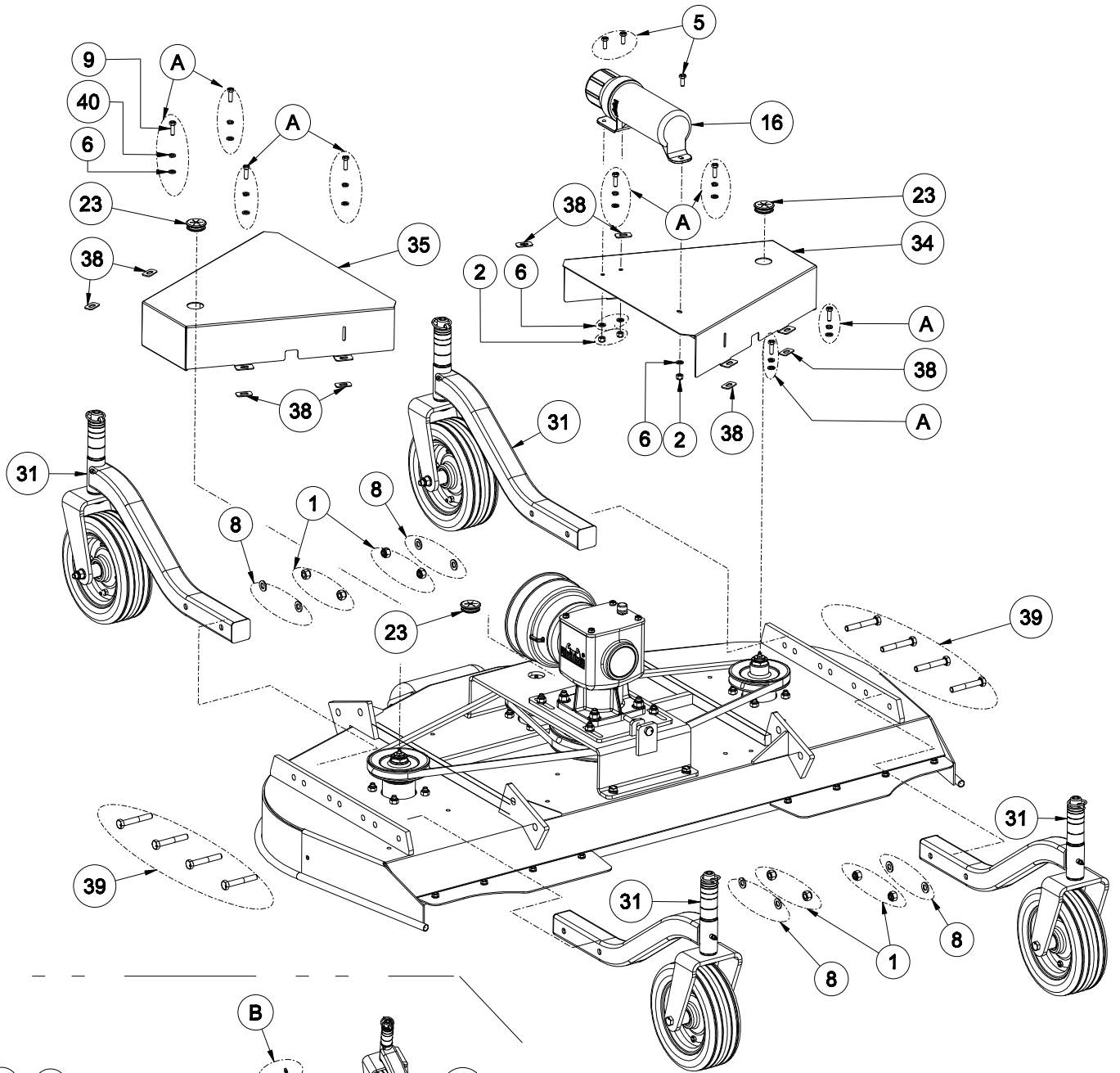

KIT FRAME ASSEMBLY FOR 1.2M ONLY

[SGM 1.2]

KIT FRAME ASSEMBLY

Sr No.	Part no	Description	Qty.
1	1209	NYLOCK NUT M12X1.75 (DIN-982)(SGM 2.1)	12
	1209	NYLOCK NUT M12X1.75 (DIN-982)(SGM 1.8)	12
	1209	NYLOCK NUT M12X1.75 (DIN-982)(SGM 1.5)	12
	1209	NYLOCK NUT M12X1.75 (DIN-982)(SGM 1.2)	10
2	1297	NYLOCK NUT M8X1.25 (DIN-982)(SGM 2.1)	13
	1297	NYLOCK NUT M8X1.25 (DIN-982)(SGM 1.8)	13
	1297	NYLOCK NUT M8X1.25 (DIN-982)(SGM 1.5)	11
	1297	NYLOCK NUT M8X1.25 (DIN-982)(SGM 1.2)	11
3	1298	NYLOCK NUT M10X1.50 (DIN-982)	16
	1298	NYLOCK NUT M10X1.50 (DIN-982)(SGM 2.1)	22
4	1299	HEX NUT M10X1.50(IS 1363)(8)(ZP)	1
5	8040	HEX BOLT M8X1.25X20(IS1364-2)(8.8)(ZP)(SGM 2.1)	17
	8040	HEX BOLT M8X1.25X20(IS1364-2)(8.8)(ZP)(SGM 1.8)	17
	8040	HEX BOLT M8X1.25X20(IS1364-2)(8.8)(ZP)(SGM 1.5)	15
	8040	HEX BOLT M8X1.25X20(IS1364-2)(8.8)(ZP)(SGM 1.2)	15
6	8064	PLAIN WASHER 8mm(SGM 2.1)	25
	8064	PLAIN WASHER 8mm(SGM 1.8)	25
	8064	PLAIN WASHER 8mm(SGM 1.5)	23
	8064	PLAIN WASHER 8mm(SGM 1.2)	23
7	8078	PLAIN WASHER 10MM (BS-4320)	8
8	8126	PLAIN WASHER 12MM (BS-4320)(SGM 2.1)	12
	8126	PLAIN WASHER 12MM (BS-4320)(SGM 1.8)	12
	8126	PLAIN WASHER 12MM (BS-4320)(SGM 1.5)	12
	8126	PLAIN WASHER 12MM (BS-4320)(SGM 1.2)	10
9	8171	HEX BOLT M8X1.25X25(IS1364-2)(8.8)(ZP)	8
10	1425	SIMS (DIA 45 X 35)(1.0MM)	1
11	2607	CSK BOLT M12 X 1.75 X 45	4
12	18168	KEY 8 X 7 X 32	3
13	6559	GREASE NIPPLE M8 X 1	3
14	3340	HEX BOLT M10X1.50X30(DIN933)(8.8)(ZP)(SGM 2.1)	4
	3340	HEX BOLT M10X1.50X30(DIN933)(8.8)(ZP)(SGM 1.8)	4
	3340	HEX BOLT M10X1.50X30(DIN933)(8.8)(ZP)(SGM 1.5)	4
	3340	HEX BOLT M10X1.50X30(DIN933)(8.8)(ZP)(SGM 1.2)	4
15	3345	HEX BOLT M10X1.50X35(DIN931)(8.8)(ZP)(SGM 2.1)	12
	3345	HEX BOLT M10X1.50X35(DIN931)(8.8)(ZP)(SGM 1.8)	12
	3340	HEX BOLT M10X1.50X30(DIN933)(8.8)(ZP)(SGM 1.5)	12
	3340	HEX BOLT M10X1.50X30(DIN933)(8.8)(ZP)(SGM 1.2)	12
16	1616	CONTAINER FOR MANUAL	1
17	25745	ROUND HEAD SQ. NECK BOLT M10 X 1.5 X 35	4
18	17788	PTO SHAFT GUARD PLASTIC	1
19	33011	HEX BOLT M10X1.50X120(DIN933)(8.8)(ZP)(SGM 2.1)	1
	33011	HEX BOLT M10X1.50X120(DIN933)(8.8)(ZP)(SGM 1.8)	1
	33108	HEX BOLT M10X1.50X90(DIN933)(8.8)(ZP)(SGM 1.5)	1
	33102	HEX BOLT M10X1.50X75(DIN933)(8.8)(ZP)(SGM 1.2)	1
20	33188	FRAME WELDMENT (SGM-2.1M) V1 (NEW)	1
	33189	FRAME WELDMENT (SGM-1.8M) V1 (NEW)	1
	33190	FRAME WELDMENT (SGM-1.5M) V1 (NEW)	1
	33191	FRAME WELDMENT (SGM-1.2M) V1 (NEW)	1
21	33184	GEARBOX SUPPORT WELDMENT (SGM-2.1M) V1	1
	33187	GEARBOX SUPPORT WELDMENT (SGM-1.8M) V1	1
	33186	GEARBOX SUPPORT WELDMENT (SGM-1.5M) V1	1
	33185	GEARBOX SUPPORT WELDMENT (SGM-1.2M) V1	1
22	33020	GEARBOX SUPPORT PLATE (SGM)	1
23	33021	ZERK CAP (SGM)	3
24	33155	SPINDLE ASSEMBLY (6206 BEARINGS)(SGM) V1	3
	33158	SPINDLE ASSEMBLY (6205 BEARINGS)(SGM) V1	3
	33196	SPINDLE ASSEMBLY (6206) (SGM 2.1) (V1)	3
25	33110	SET OF SPB BELT LD=2340 (2 NOS)(SGM 2.1)	1
	33111	SET OF SPB BELT LD=1950(2 NOS)(SGM 1.8)	1
	33052	SET OF SPB BELT LD=1750(2 NOS)(SGM 1.5)	1
	33051	SET OF SPB BELT LD=1500(2 NOS)(SGM 1.2)	1

KIT FRAME ASSEMBLY

Sr No.	Part no	Description	Qty.
26	33054	PARALLEL KEY 10 X 8 X 40	1
27	33175	BLADE,MOWER 60 X 6 X L-730 (SGM-2.1M) V1	3
	33178	BLADE,MOWER 60 X 6 X L-616 (SGM-1.8M) V1	3
	33177	BLADE,MOWER 60 X 6 X L-515.5(SGM-1.5M)V1	3
	33176	BLADE,MOWER 60 X 6 X L-424 (SGM-1.2M) V1	3
28	33002	SPB TYPE PULLEY PCD=160, 1 GROOVE (SGM)(SGM 2.1)	2
	33059	SPB TYPE PULLEY PCD=130, 1 GROOVE (SGM)(SGM 1.8)	2
	33059	SPB TYPE PULLEY PCD=130, 1 GROOVE (SGM)(SGM 1.5)	2
	33058	SPB TYPE PULLEY PCD=110, 1 GROOVE (SGM)(SGM 1.2)	2
29	33003	SPB TYPE PULLEY PCD=160, 2 GROOVE (SGM)(SGM 2.1)	1
	33061	SPB TYPE PULLEY PCD=130, 2 GROOVE (SGM)(SGM 1.8)	1
	33061	SPB TYPE PULLEY PCD=130, 2 GROOVE (SGM)(SGM 1.5)	1
	33060	SPB TYPE PULLEY PCD=110, 2 GROOVE (SGM)(SGM 1.2)	1
30	33004	SPB TYPE PULLEY PCD=212, 2 GROOVE (SGM)(SGM 2.1)	1
	33063	SPB TYPE PULLEY PCD=190, 2 GROOVE (SGM)(SGM 1.8)	1
	33062	SPB TYPE PULLEY PCD=225, 2 GROOVE (SGM)(SGM 1.5)	1
	33062	SPB TYPE PULLEY PCD=225, 2 GROOVE (SGM)(SGM 1.2)	1
31	33181	TUBE ASM. SOLID TYRE 10X3.25"(10MM)(SGM V1)	4
32	33079	WASHER, DRIVING PULLEY 25X56X6 (SGM)	1
33	33085	GEAR BOX ASSEMBLY(SGM)	1
34	33086	BELT COVER WELDMENT RH-(SGM-2.1)	1
	33092	BELT COVER WELDMENT RH-(SGM-1.8)	1
	33090	BELT COVER WELDMENT RH-(SGM-1.5)	1
	33088	BELT COVER WELDMENT RH-(SGM-1.2)	1
35	33087	BELT COVER WELDMENT LH-(SGM-2.1)	1
	33093	BELT COVER WELDMENT LH-(SGM-1.8)	1
	33091	BELT COVER WELDMENT LH-(SGM-1.5)	1
	33089	BELT COVER WELDMENT LH-(SGM-1.2)	1
36	33099	WASHER SCHNNOR M10 (SGM)	4
37	33100	WASHER SCHNNOR M18 (SGM)	3
38	33101	GASKET, BELT COVER (SGM)	8
39	33103	HEX BOLT M12X1.75X80(DIN931)(8.8)(ZP)(SGM 2.1)	8
	33103	HEX BOLT M12X1.75X80(DIN931)(8.8)(ZP)(SGM 1.8)	8
	33103	HEX BOLT M12X1.75X80(DIN931)(8.8)(ZP)(SGM 1.5)	8
	33103	HEX BOLT M12X1.75X80(DIN931)(8.8)(ZP)(SGM 1.2)	4
40	14360	SPRING WASHER M8.00(IS 3063)(ZP)	8
41	33139	NYLOCK NUT M25 X 1.5	4
42	33138	NYLOCK NUT M18 X 1.5 (DIN-985)	3
43	33145	REAR SAFETY GUARD (SGM 2.1M)	2
	33146	REAR SAFETY GUARD (SGM 1.8M)	2
	33147	REAR SAFETY GUARD (SGM 1.5M)	2
	33148	REAR SAFETY GUARD (SGM 1.2M)	2
44	33037	HEX BOLT M12X1.75X135(DIN931)(8.8)(ZP)	2
45	6603	HEX BOLT M10X1.50X35(DIN933)(8.8)(ZP)	6

GEAR BOX ASSEMBLY

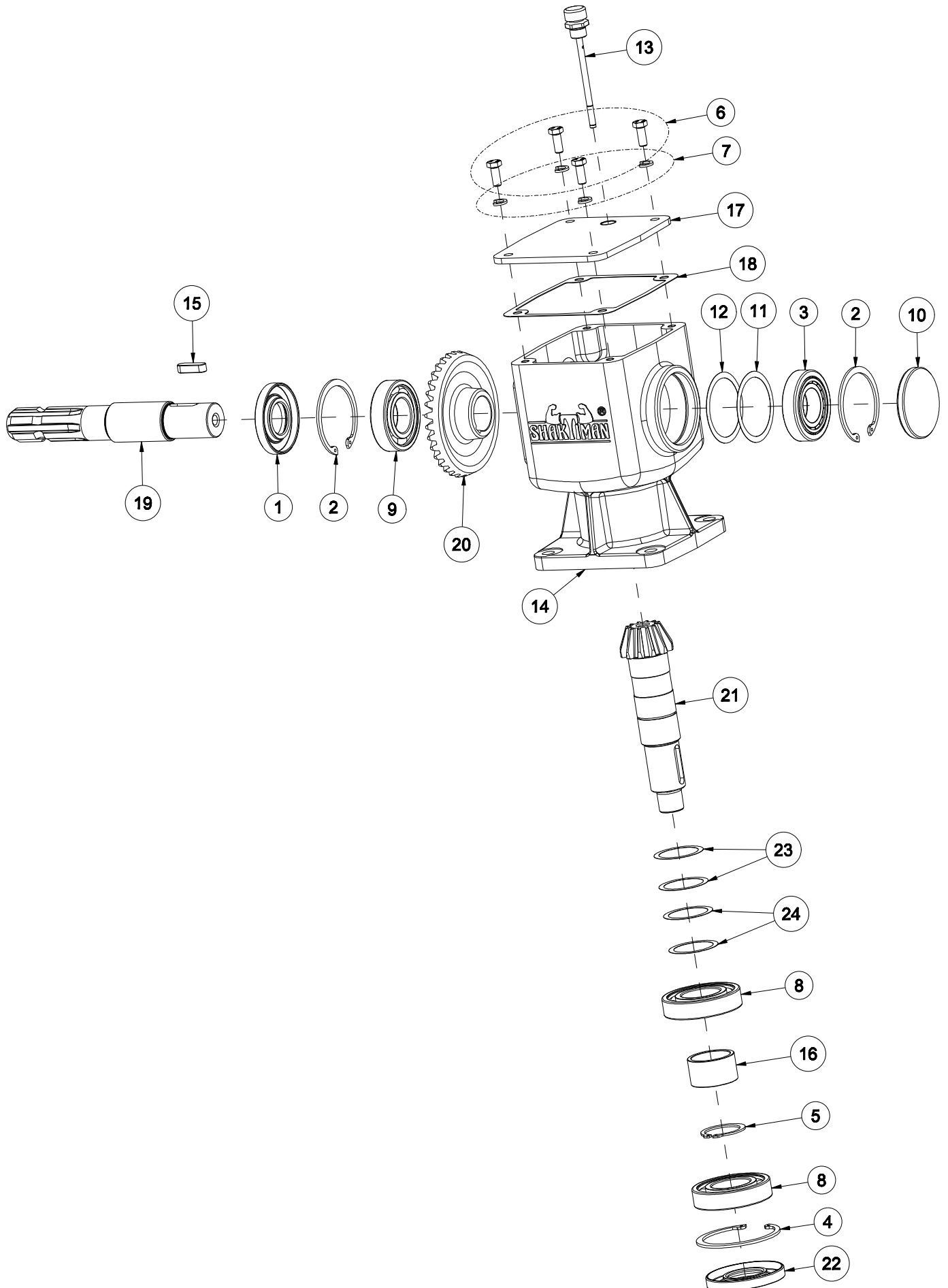

GEAR BOX ASSEMBLY

Sr No.	Part no	Description	Qty.
1	1001	OIL SEAL 35 X 72 X 10	1
2	1002	CIRCLIP INTERNAL 72mm	2
3	1003	BEARING 30207	1
4	1130	CIRCLIP INTERNAL 80mm	1
5	8027	CIRCLIP EXTERNAL 40mm	1
6	8040	HEX BOLT M8X1.25X20(IS1364-2)(8.8)(ZP)	4
7	14360	SPRING WASHER M8.00(IS 3063)(ZP)	4
8	7033	BEARING 6208	2
9	10143	BEARING 6207	1
10	14119	OIL SEAL 72X8	1
11	4652	SIMS (DIA 72 X 60)(0.20mm)	1
12	4653	SIMS (DIA 72 X 60)(0.30mm)	1
13	14316	DIPSTICK 106MM (M16 X 1.5) (1MLSR202)	1
14	33005	GEAR BOX HOUSING (SGM)	1
15	33050	PARALLEL KEY 10 X 8 X 32	1
16	33078	SPACER, PINION 40X48X28 (SGM)	1
17	33080	GEARBOX COVER (SGM)	1
18	33081	GASKET, GEARBOX COVER (SGM)	1
19	33082	INPUT SHAFT, (SGM)	1
20	33083	BEVEL GEAR Z-34 TEETH (SGM)	1
21	33084	BEVEL PINION SHAFT 12 TEETH (SGM)	1
22	35005	OIL SEAL 40 X 80 X 10 (MAX)	1
23	17621	SHIMS (DIA 50 X 40.5)(0.20MM)	2
24	17622	SHIMS (DIA 50 X 40.5)(0.30MM)	2

SPINDLE ASSEMBLY (6205/6206)

PLEASE NOTE: All SGM Finishing Mowers imported into Australia have 6206 bearings

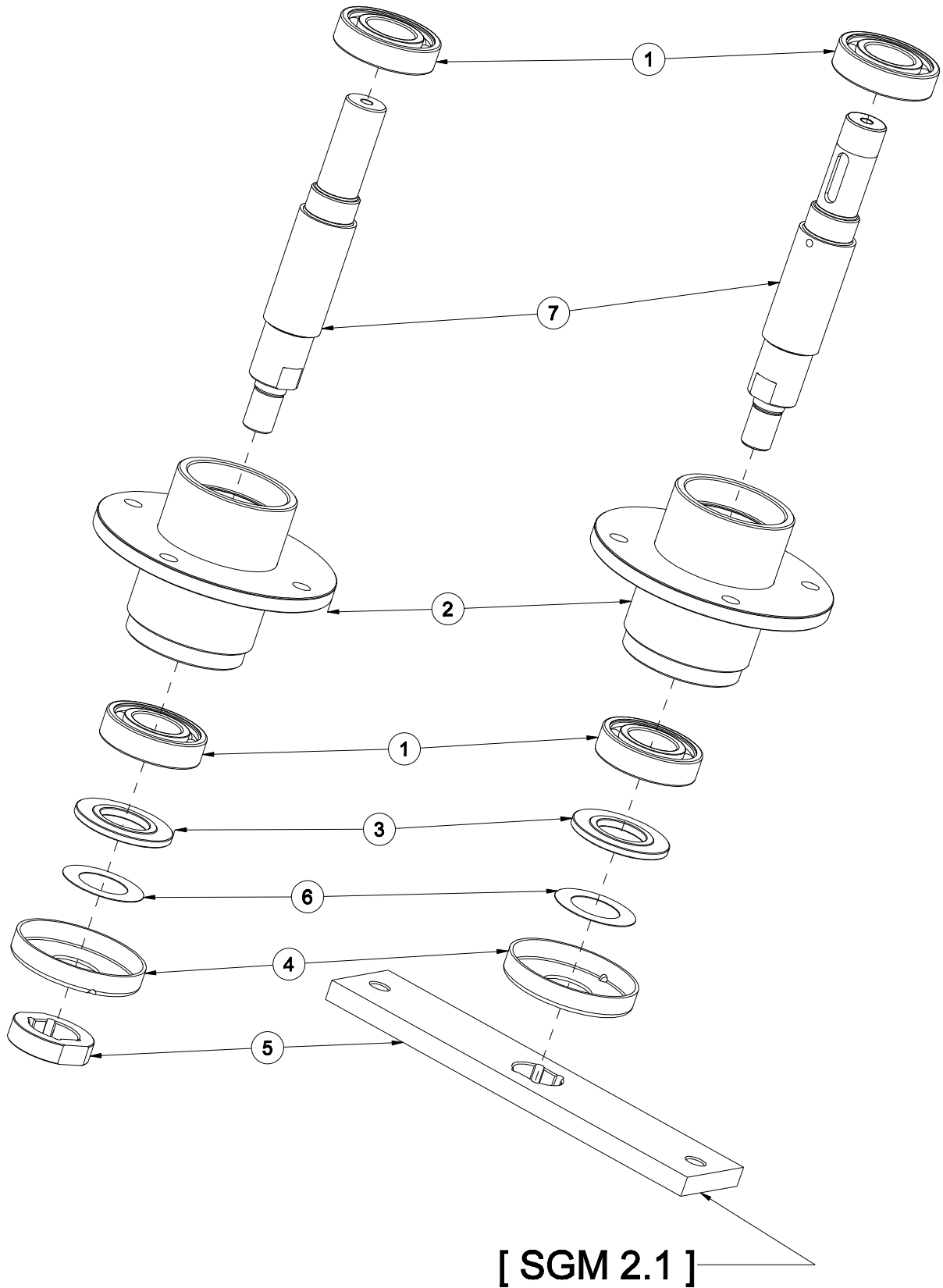

SPINDLE ASSEMBLY (6205/6206)

Sr No.	Part no	Description	Qty.
1	8105	BEARING 6205 2RS	2
	12210	BEARING 6206 2RS	2
2	33044	SPINDLE (BEARINGS 6205) (SGM)	1
	33038	SPINDLE (BEARINGS 6206) (SGM)	1
3	33045	SPACER WASHER 25X40X3 (6205) (SGM)	1
	33040	SPACER WASHER (30X60X5) (6206) (SGM)	1
4	33046	DUST PROTECTION COVER (6205) (SGM)	1
	33041	DUST PROTECTION COVER (6206) (SGM)	1
5	33047	BUSHING, BLADE TIGHTENING (6205) (SGM)	1
	33042	BUSHING, BLADE TIGHTENING (6206) (SGM)	1
	33195	BLADE SUPPORT PLATE (6206) (SGM 2.1)(V1)	1
6	33180	SIMS (DIA 50 X 30.3)(0.5 mm) (6206)	1
7	33194	SHAFT,SPINDLE NEW (6205 BEARINGS)(SGM)V1	1
	33193	SHAFT,SPINDLE NEW (6206 BEARINGS)(SGM)V1	1

WHEEL ASSEMBLY

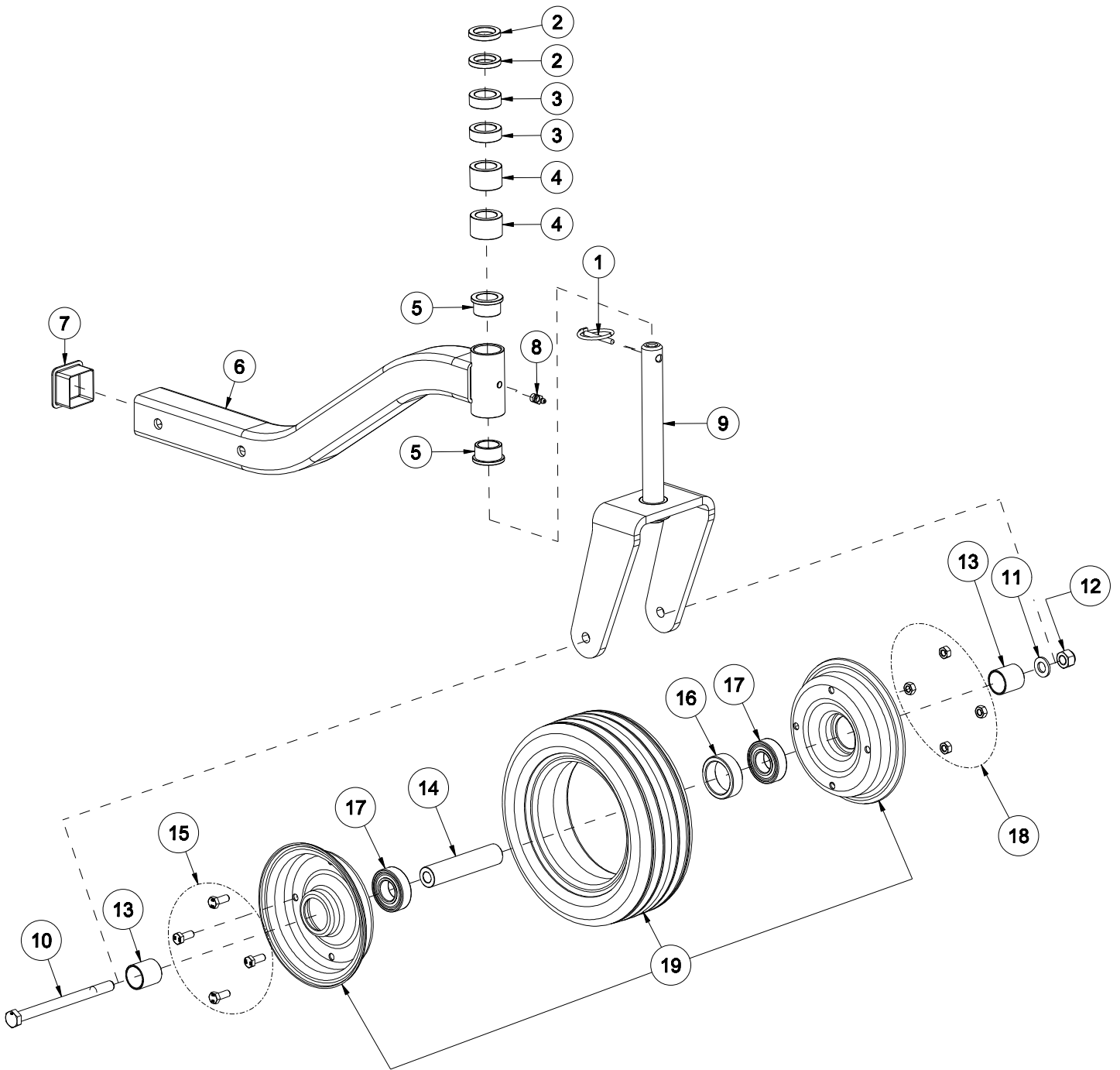

WHEEL ASSEMBLY

Sr No.	Part no	Description	Qty.
1	8204	LINCH PIN SMALL (CHO)	1
2	33073	SPACER 25X32X6 (SGM)	2
3	33074	SPACER 25X32X12.5 (SGM)	2
4	33075	SPACER 25X32X25 (SGM)	2
5	33007	PLASTIC BEARING MFM-2532-20	2
6	33064	WHEEL HALF-ARM WELDMENT (SGM)	1
7	23163	SQ. PIPE PLASTIC CAP 50MM	1
8	20148	GREASE NIPPLE M8 X 1.25	1
9	33141	WHEEL YOKE REINF. WELD.(SGM) V1	1
10	33154	HEX BOLT M12X1.75X160(DIN931)(8.8)(ZP)	1
11	8126	PLAIN WASHER 12MM (BS-4320)	1
12	1209	NYLOCK NUT M12X1.75 (DIN-982)	1
13	33143	SPACER, SOLID TYRE(30X26X31) (SGM)	2
14	33142	WHEEL MOUNTING PIPE NEW (SGM)	1
15	8040	HEX BOLT M8X1.25X20(IS1364-2)(8.8)(ZP)	4
16	33065	SPACER 52X40X17 (SGM)	1
17	8105	BEARING 6205 2RS	2
18	8181	HEX NUT M8X1.25(IS 1363)(8)(ZP)	4
19	33008	SOLID TYRE 10"X3.25" (SGM)	1

KIT 3- POINT ATTACHMENT

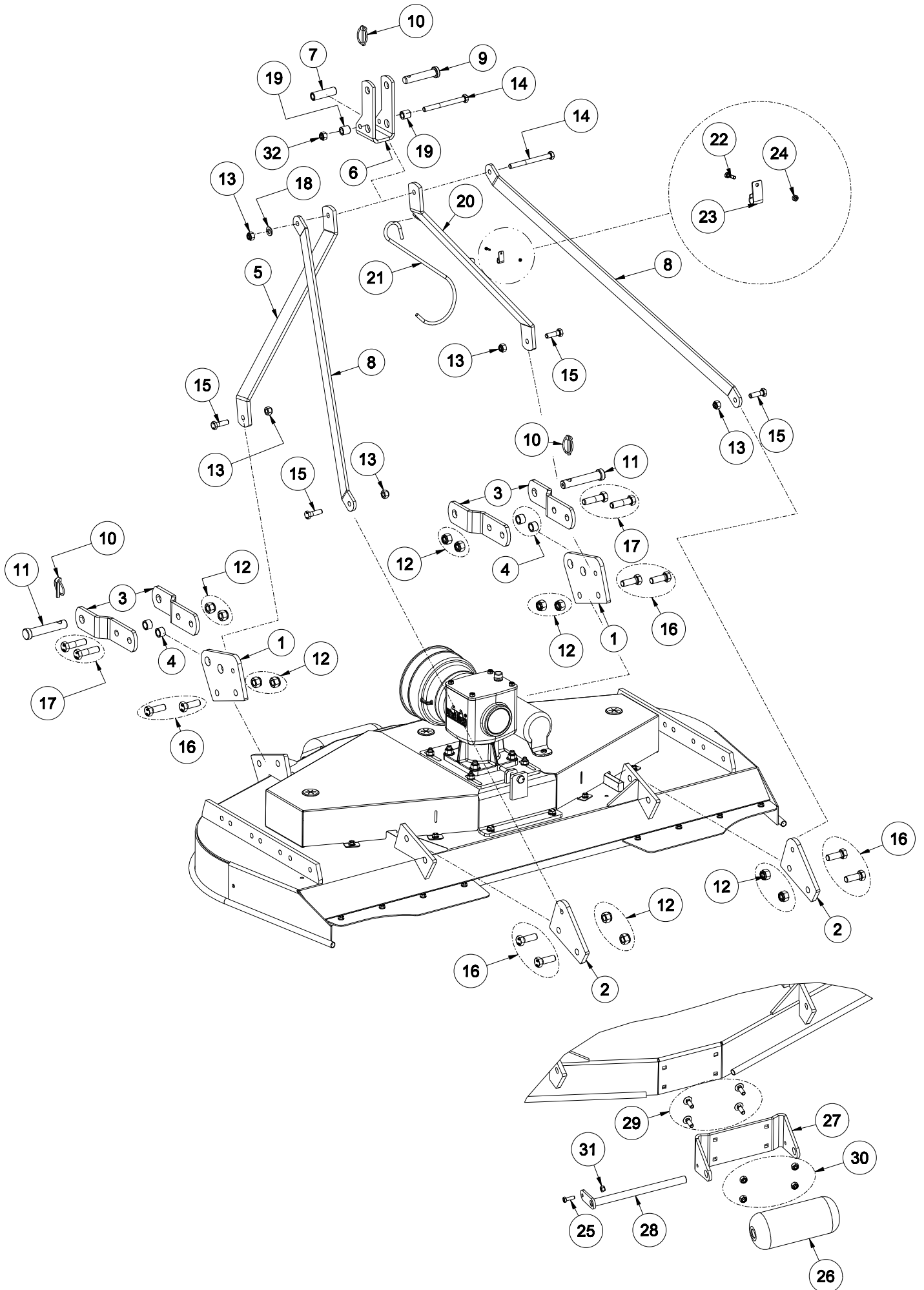

KIT 3- POINT ATTACHMENT

Sr No.	Part no	Description	Qty.
1	33025	CONNECTION PLATE, FRONT (SGM)	2
2	33026	CONNECTION PLATE, REAR (SGM)	2
3	33144	LOWER HITCH (SGM)	4
4	33027	BUSHING, LOWER HITCH (SGM)	4
5	33028	TOP HITCH SUPPORT (LH) (SGM)	1
6	33029	COUPLING, UPPER 3-POINT HITCH (SGM)	1
7	33030	SPACER, UPPER 3 POINT HITCH (SGM)	1
8	33031	TOP HITCH ARM (SGM-2.1M)	2
	33032	TOP HITCH ARM, (SGM-1.2M)	2
	33033	TOP HITCH ARM (SGM-1.5M)	2
	33034	TOP HITCH ARM (SGM-1.8M)	2
9	33036	PIN, TOP HITCH (CATEGORY I) (SGM)	1
10	1218	LINCH PIN	3
11	1216	HITCH PIN BOTTOM CAT-I (DIA-22 X 129)	2
12	1231	NYLOCK NUT M16X2.0 (DIN-982)	12
13	1209	NYLOCK NUT M12X1.75 (DIN-982)	5
14	33104	HEX BOLT M12X1.75X130(DIN931)(8.8)(ZP)	2
15	3343	HEX BOLT M12X1.75X40(DIN931)(8.8)(ZP)	4
16	8196	HEX BOLT M16X2.00X45(IS1364-1)(8.8)(ZP)	8
17	18446	HEX BOLT M16X2.00X55(IS1364-1)(8.8)(ZP)	4
18	8126	PLAIN WASHER 12MM (BS-4320)	1
19	33115	BUSH 21X13X22 (SGM)	2
20	33117	TOP HITCH SUPPORT WELDMENT (SGM)	1
21	14340	DRIVELINE HOOK 250MM	1
22	23029	HEX BOLT M4X0.75X10(IS1364-2)(8.8)(ZP)	1
23	23147	PLATE,HOOK HOLDING (JUMBO)	1
24	23028	HEX NUT M4X0.75(IS 1363)(8)(ZP)	1
25	8171	HEX BOLT M8X1.25X25(IS1364-2)(8.8)(ZP)	1
26	33024	FRONT ROLLER, AIR WHEELS (SGM)	1
27	33179	BRACKET, FRONT ROLLER (SGM) V1	1
28	33022	ROD WELDMENT, FRONT ROLLER (SGM)	1
29	8174	RO HD SQ NECK BOLT M10 X 1.5 X 30 FT-8.8	4
30	1298	NYLOCK NUT M10X1.50 (DIN-982)	4
31	33138	NYLOCK NUT M18 X 1.5 (DIN-985)	1
32	33197	NYLOC NUT M12X1.75 (GR.8) DIN982 TYP	1

MULCHING KIT ASSEMBLY

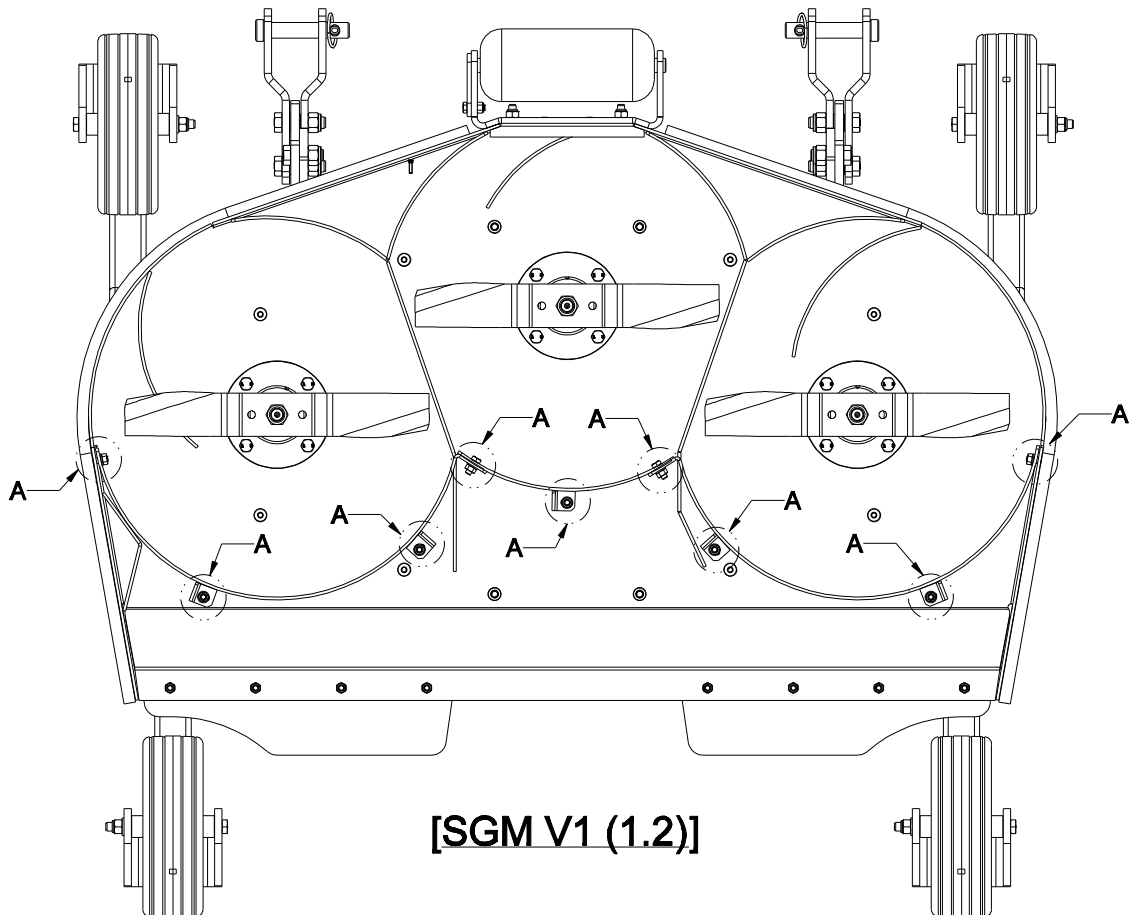
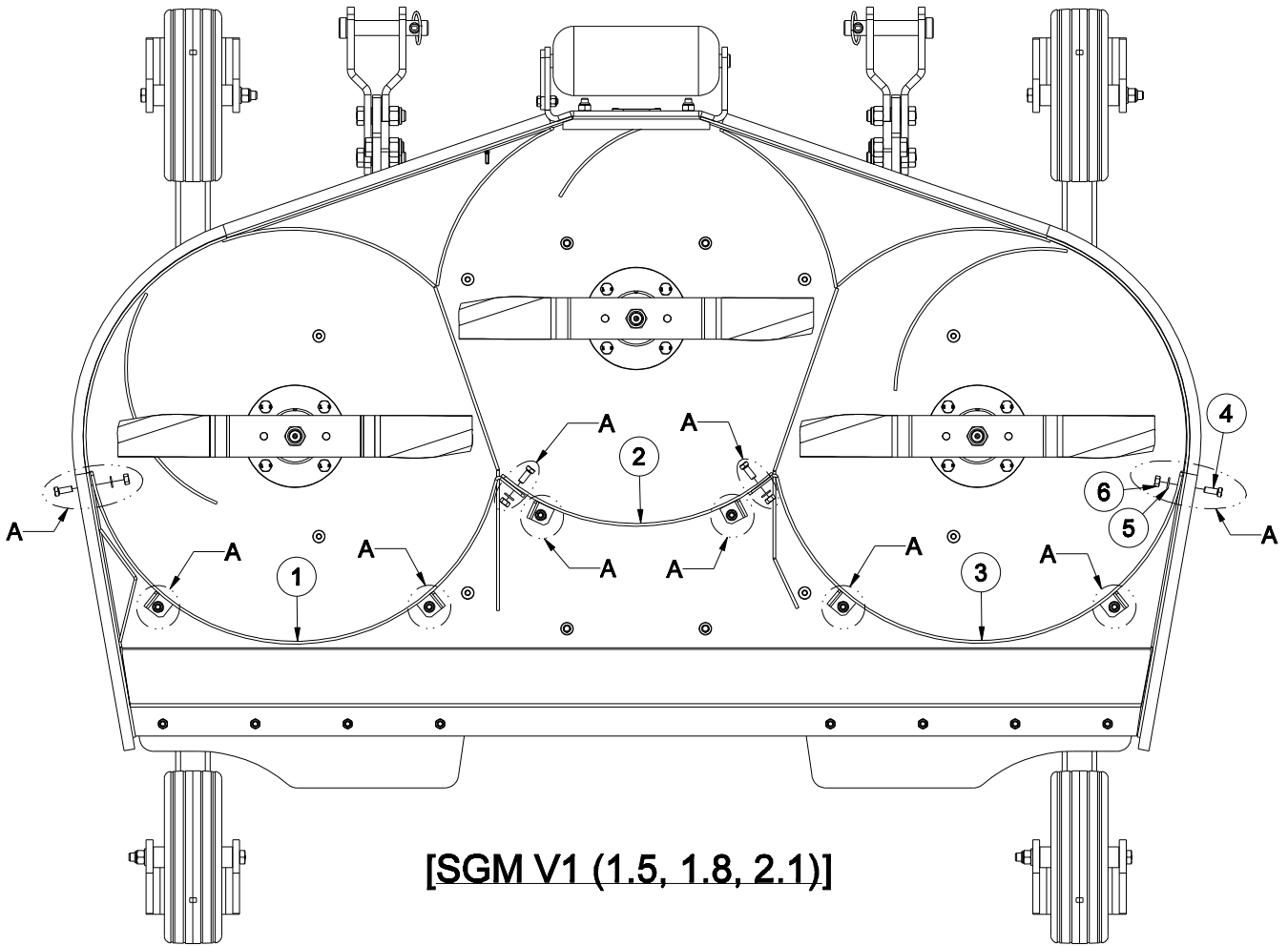

MULCHING KIT ASSEMBLY

Sr No.	Part no	Description	Qty.
1	33161	CONTAINING PLATE WELDMENT LH(SGM-1.2M)V1	1
	33164	CONTAINING PLATE WELDMENT LH(SGM-1.5M)V1	1
	33167	CONTAINING PLATE WELDMENT LH(SGM-1.8M)V1	1
	33170	CONTAINING PLATE WELDMENT LH(SGM-2.1M)V1	1
2	33160	CONTAINING PLATE WELD MIDDLE(SGM-1.2M)V1	1
	33163	CONTAINING PLATE WELD MIDDLE(SGM-1.5M)V1	1
	33166	CONTAINING PLATE WELD MIDDLE(SGM-1.8M)V1	1
	33169	CONTAINING PLATE WELD MIDDLE(SGM-2.1M)V1	1
3	33159	CONTAINING PLATE WELDMENT RH(SGM-1.2M)V1	1
	33162	CONTAINING PLATE WELDMENT RH(SGM-1.5M)V1	1
	33165	CONTAINING PLATE WELDMENT RH(SGM-1.8M)V1	1
	33168	CONTAINING PLATE WELDMENT RH(SGM-2.1M)V1	1
4	24117	HEX BOLT M8X1.25X20(IS1364-2)(8.8)(ZP)(SGM 1.2)	9
	24117	HEX BOLT M8X1.25X20(IS1364-2)(8.8)(ZP)(SGM 1.5)	10
	24117	HEX BOLT M8X1.25X20(IS1364-2)(8.8)(ZP)(SGM 1.8)	10
	24117	HEX BOLT M8X1.25X20(IS1364-2)(8.8)(ZP)(SGM 2.1)	10
5	8064	PLAIN WASHER 8MM (BS-4320)(SGM 1.2)	9
	8064	PLAIN WASHER 8MM (BS-4320)(SGM 1.5)	10
	8064	PLAIN WASHER 8MM (BS-4320)(SGM 1.8)	10
	8064	PLAIN WASHER 8MM (BS-4320)(SGM 2.1)	10
6	25597	HEX NUT M8X1.25(IS 1363)(8)(ZP)(SGM 1.2)	9
	25597	HEX NUT M8X1.25(IS 1363)(8)(ZP)(SGM 1.5)	10
	25597	HEX NUT M8X1.25(IS 1363)(8)(ZP)(SGM 1.8)	10
	25597	HEX NUT M8X1.25(IS 1363)(8)(ZP)(SGM 2.1)	10
7	33171	MULCHING KIT ASSEMBLY (SGM-1.2M) V1	1
	33172	MULCHING KIT ASSEMBLY (SGM-1.5M) V1	1
	33173	MULCHING KIT ASSEMBLY (SGM-1.8M) V1	1
	33174	MULCHING KIT ASSEMBLY (SGM-2.1M) V1	1

MULCHING KIT

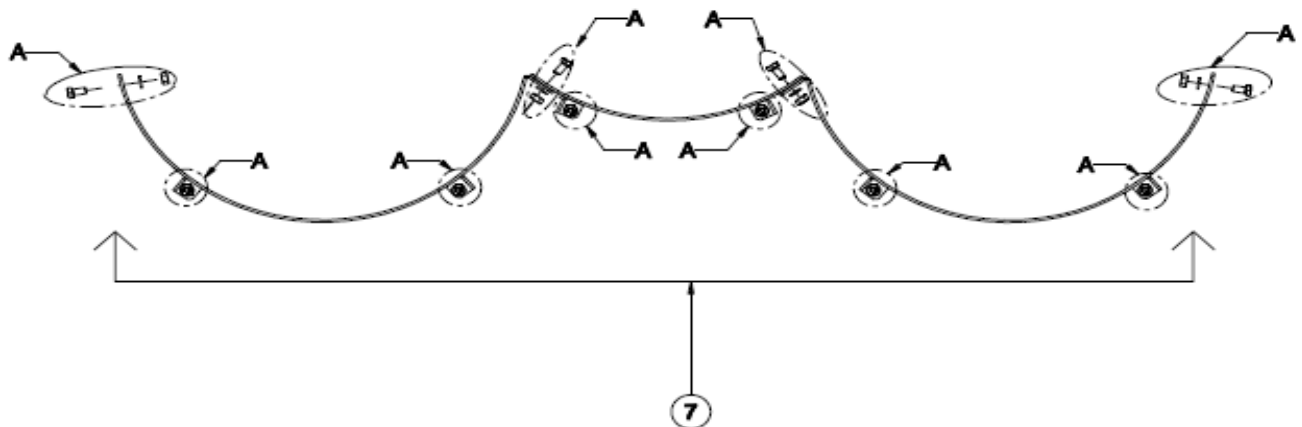

NOTES:

A series of 25 horizontal dotted lines for writing notes.

NOTES:

A series of 20 horizontal dotted lines for writing notes.



FARM IMPLEMENTS Pty Ltd
12 Tarmac Way
Pakenham Victoria
AUSTRALIA 3810
+61 3 9706 5166
sales@farmimplements.com.au
www.farmimplements.com.au