

# M120 Series Power Harrow



Engineered in Europe, the BULLY M120 Series Power Harrows are heavy-duty machines for professional operators with tractors from 100 to 160hp. The M120 Series Power Harrow is equipped with a raft of features for efficient operation, including a 160hp rated (540/1000rpm) multi-speed gearbox, rear levelling bar and floating side plates.

The power harrow features a centrally mounted tower constructed from folded metal components, reinforced and welded to create a robust one-piece design that securely bolts to the deck. The fully welded and reinforced main frame ensures precise alignment of blade spindles and gears horizontally.

With their advanced blade design and action, the M120 Power Harrows finely work the soil to a maximum depth of 285mm in fewer passes. This minimises ground compaction, reduces fuel consumption and places less load and demand on the tractor, making it an ideal choice for professional farming.

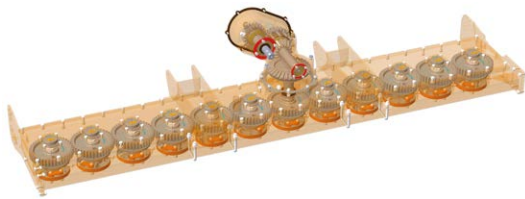

### Transmission

A series of blade spindles counter-rotate on a vertical axis. Gears are aligned horizontally for maximum contact and power transfer between blade spindles.

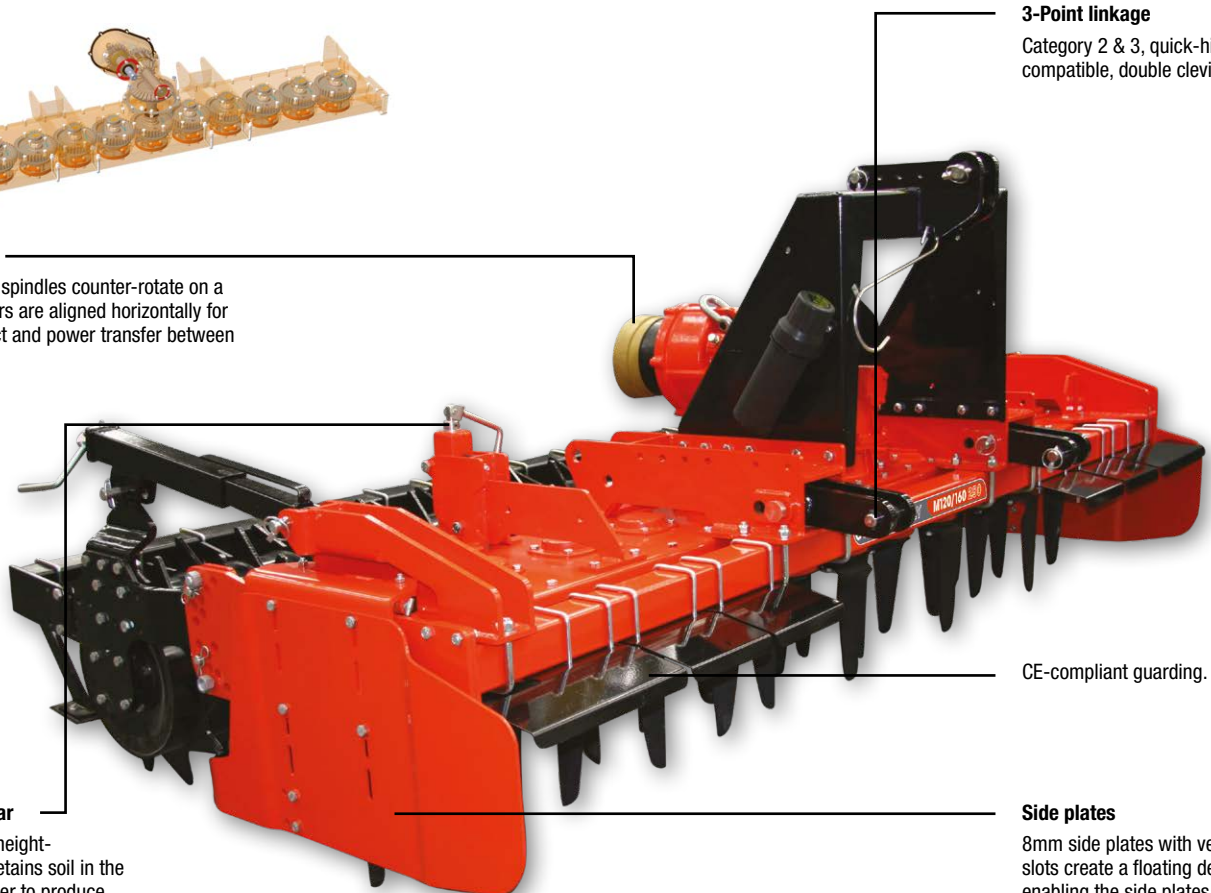

### 3-Point linkage

Category 2 & 3, quick-hitch compatible, double clevis mount.

### CE-compliant guarding

### Rear levelling bar

The mechanical height-adjustment bar retains soil in the chamber for longer to produce finely-tilled soil. Additionally, it functions as a scraper, leaving a smooth finish.

### Side plates

8mm side plates with vertical slots create a floating design, enabling the side plates to follow the contours of the ground.

Code	TM120/160-250	TM120/160-300
Size reference	2.5m   8'2"   98"	3.0m   9'10"   118"
Gearbox	160hp, 540/1000rpm, multi-speed	
PTO shaft/clutch	Series W2600 with 200mm (8") friction clutch	
No. of rotors	10	12
Total no. of blades	20	24
Blades	295 x 12mm	
Overall width (mm)	2600	3100
Working width (mm)	2500	3000
Working depth (mm)	285	
Tractor range (hp)	100 - 160   84 - 134 @ PTO	120 - 160   100 - 134 @ PTO
Weight (kg)	850	950

BULLY M120 Series Power Harrows are equipped with long blades that facilitate a range of tilling depths from shallow (20 - 50mm) to deep (285mm). Operators seeking to till the top 20 - 50mm, for pasture renovation or due to limited quality topsoil, can pre-set the desired working depth by fitting an optional cage or packer roller to the harrow.

## M120 Cage Rollers

Cage rollers are highly effective in dry, non-sticky or slightly damp soils. If your soil falls into these conditions, opting for a cage roller would be a smart choice to achieve the desired depth and seedbed quality during preparation.

Featuring a Ø450mm, twisted, and reinforced eight (8) bar design, the roller is equipped with a user-friendly multi-position positive locking pin-and-clip height adjustment system that includes a mechanical ratchet screw adjuster. This allows for quick and effortless adjustments while the roller pivots off a single front point for added convenience.

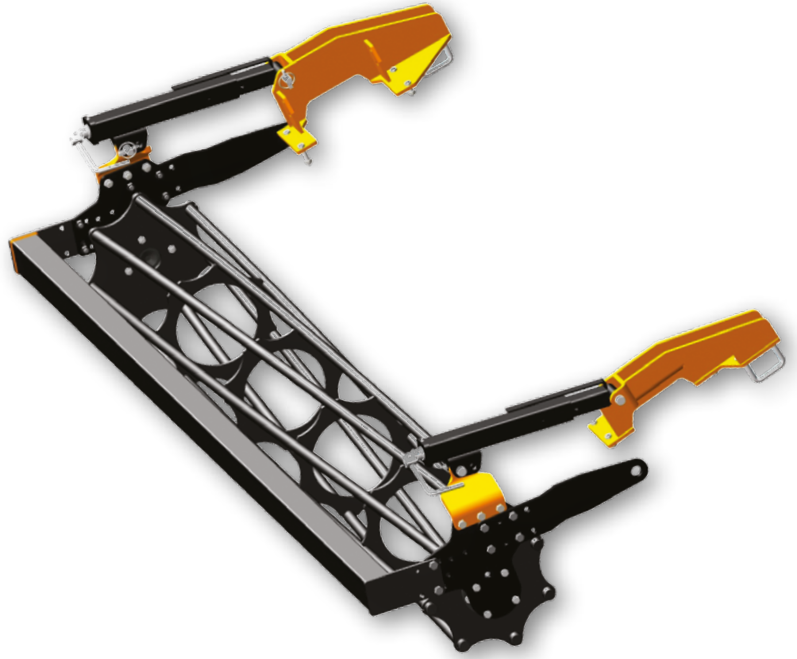

Code	TM120/160-250CR	TM120/160-300CR
Description	Bully M120-250 Cage Roller	Bully M120-300 Cage Roller
Weight (kg)	145	166



## M120 Packer Rollers

Packer rollers are versatile and well-suited for all soil types. They create beneficial grooves in the soil that aid in drainage, while individual scrapers, strategically placed between each row of teeth, effectively remove stickier soils.

The packer roller design features a Ø500mm solid pipe with welded shark fin-shaped teeth on 80mm spacings, equipped with scrapers. It also includes a multi-position positive locking pin-and-clip height adjustment system, that includes a mechanical ratchet screw adjuster, for easy and precise adjustments.

Code	TM120/160-250PR	TM120/160-300PR
Description	Bully M120-250 Packer Roller	Bully M120-300 Packer Roller
Weight (kg)	305	360